

交通量調査結果

中町入口

【休日・実験H30・通常時】

【自動車】

4

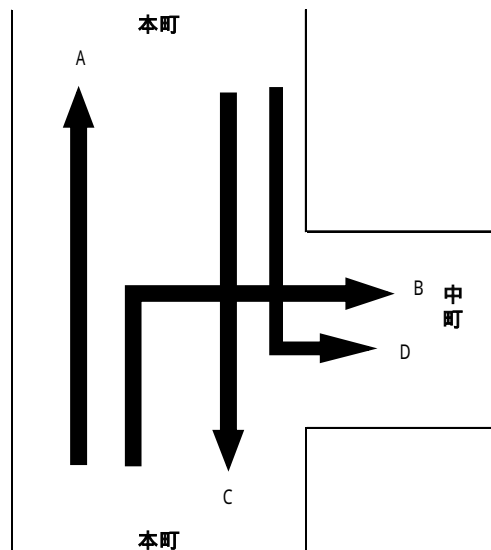

	A 本町北上				B 中町右折				C 本町南下				D 中町左折			
	H30.8.26 (日)	H30.9.2 (日)	比率	増減	H30.8.26 (日)	H30.9.2 (日)	比率	増減	H30.8.26 (日)	H30.9.2 (日)	比率	増減	H30.8.26 (日)	H30.9.2 (日)	比率	増減
7:00 ~ 8:00	104	117	113%	13	59	51	86%	8	101	156	154%	55	31	37	119%	6
8:00 ~ 9:00	178	191	107%	13	98	81	83%	17	214	192	90%	22	75	53	71%	22
9:00 ~ 10:00	249	241	97%	8	134	109	81%	25	271	259	96%	12	110	114	104%	4
10:00 ~ 11:00	278	298	107%	20	145	199	137%	54	278	309	111%	31	127	126	99%	1
11:00 ~ 12:00	275	297	108%	22	125	162	130%	37	334	338	101%	4	113	110	97%	3
12:00 ~ 13:00	309	265	86%	44	179	140	78%	39	341	310	91%	31	141	144	102%	3
13:00 ~ 14:00	291	283	97%	8	136	142	104%	6	308	334	108%	26	112	114	102%	2
14:00 ~ 15:00	281	287	102%	6	146	143	98%	3	352	340	97%	12	98	129	132%	31
15:00 ~ 16:00	304	314	103%	10	134	160	119%	26	350	387	111%	37	113	126	112%	13
16:00 ~ 17:00	304	296	97%	8	133	148	111%	15	388	301	78%	87	105	110	105%	5
17:00 ~ 18:00	247	267	108%	20	140	122	87%	18	342	332	97%	10	121	87	72%	34
18:00 ~ 19:00	220	227	103%	7	129	129	100%	0	314	273	87%	41	85	86	101%	1
総計	3,040	3,083	101%	43	1,558	1,586	102%	28	3,593	3,531	98%	62	1,231	1,236	100%	5
実験時間合計	2,509	2,534	101%	25	1,267	1,345	106%	78	3,007	2,924	97%	83	1,015	1,032	102%	17